

PHASE LOSS REMOTE ALARM

RFM SERIES • Model RFM - 2V

Be alerted to:

- PHASE LOSS
- LOW VOLTAGE
- BROWNOUTS
- PHASE REVERSAL*
- PHASE IMBALANCE*

*Subject to specifications of Phase Monitor



*Don't wait for motor damage
Don't search for tiny indicator lights*

The **Phase Loss REMOTE ALARM**, when used in conjunction with a Phase Loss Monitor, alerts maintenance personnel to a Phase Loss problem INSTANTLY with a simultaneous visual and audible signal, preventing costly detection delays.

The Phase Loss Monitor will shut down a single motor or a group of motors, while

the **Phase Loss REMOTE ALARM** signals with a 95db horn for a 1 - 60 minute duration (adjustable to suit your situation) and a 6-watt flashing beacon. The system resets automatically after failure or power outage. Installation is easy. See other side for system features, wiring diagram and dimensions.



OVER FOR BENEFITS AND PRICING...

SYSTEM FEATURES

- Integrated Solid State System
- Multi-rate, controlled, automatic, charger - No manual battery recycling.
- Lock Out (Automatic Battery Connect)
- Automatic Reset After Failure or Power Outage
- Low Voltage Battery Cutoff
- Dual Voltage Transformer for 120 / 277 VAC Operation
- Brown out Sensitivity
- High Intensity Tungstern Lamps, 6 Volt - 6 Watt
- Sealed Lead Calcium Battery, 6 Volt operation
- Contemporary Styling
- Beige, Powder Coat Finish; 20 Ga. Steel Cabinet.
- Test Switch
- Red (Power On) & Green (Trickle Charge) LED Indicators

TYPICAL ALARM SYSTEM:

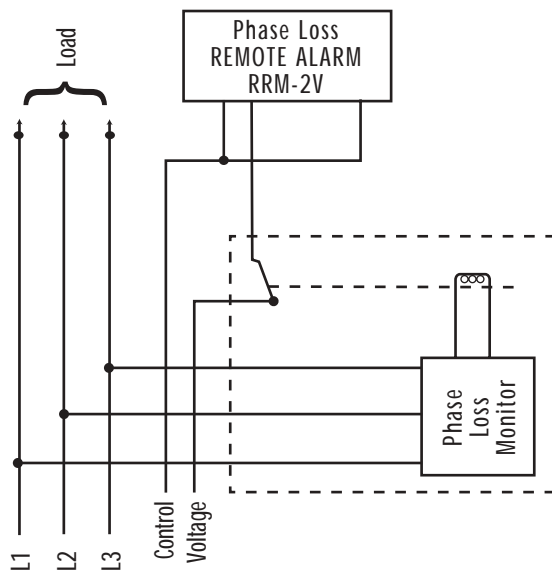

DIMENSIONS:

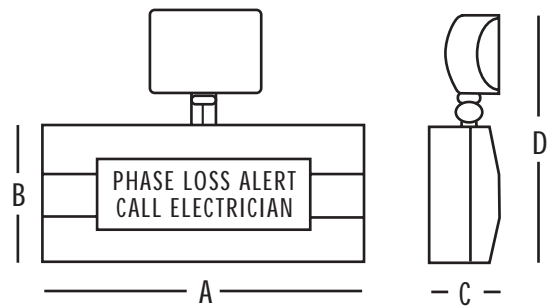

A	B	C	D
13 3/4"	5 3/4"	2 7/8"	10 3/8"



BIG BEAM EMERGENCY SYSTEMS, INC.

P.O. BOX 518 • CRYSTAL LAKE, IL 60039-0518

(815) 459-6143

FAX-(815) 459-6126

www.bigbeam.com • Email: info@bigbeam.com