

### FEATURES

- Integrated Solid State System
- Multi-Rate, Controlled, Automatic Charger
- Lock Out (Automatic Battery Connect)
- Brownout Sensitivity
- Dual-Voltage for 120/277 VAC Operation
- Sealed Lead Calcium Battery (S) or Sealed Nickel Cadmium Battery (N)
- 6 Volt Operation with 12W 90 Minute Battery Capacity Standard Maintenance-Free
- 6W Remote Capability Standard
- 20-Gauge Steel Housing
- Slim Line Styling
- Steel Lamp Heads
- Rotating & Articulating Swivels
- White Powder-Coat Finish Standard
- Red (Power On) LED Indicator
- Test Switch
- UL Listed
- Chicago Approved
- New York City Approved/Calendar #32110



### DIMENSIONS

LASER-LM:

Height: 6.0"

Width: 12.5"

Depth: 4.5"

## LASER-LM

The LASER emergency lights are a low-profile, steel-constructed unit, suitable for installation where unit size and cost are premium considerations.

### Options:

- \* **BLK** - Black Finish (Special Order)
- \* **N** - Nickel Cadmium Battery
- \* **P2** - Cord & Plug for 120VAC Input

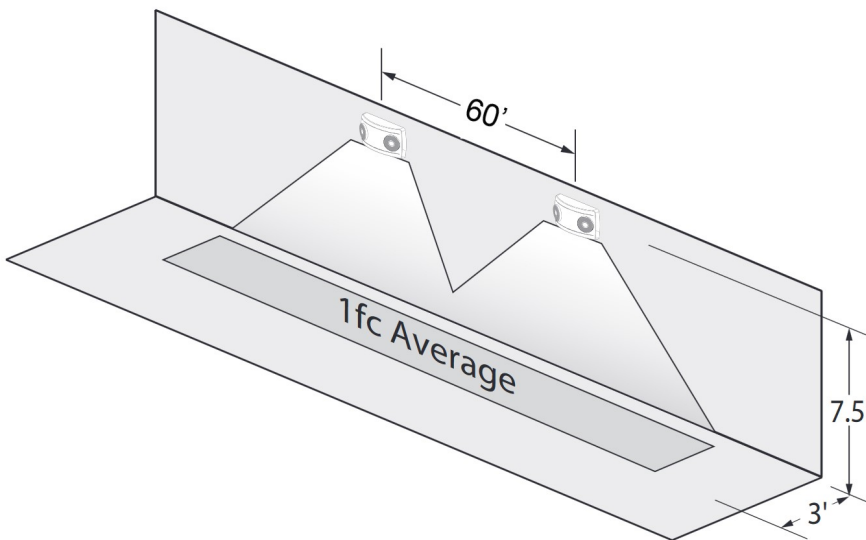

Series	Lamp Type	Options
LASER	LM = Mini LED (3W 300 Lumens per Head)	-P2 = Cord & Plug



### DIMENSIONS AS SHOWN

LASER-LM:

Height: 3.0" Width: 12.5" Depth: 5.75"