

INSTALLATION INSTRUCTIONS

CAUTION: Before installing, make certain the AC power is off and the ELB converter connector is disconnected.

1. MOUNTING THE EMERGENCY LED DRIVER

Mount the ELB to the top of the luminaire with suitable fasteners (not provided). Drill or punch a 7/8" hole (1/2" knockout) on top of luminaire for flexible conduit. Attach flexible conduit.

Refer to Figure 1 at right.

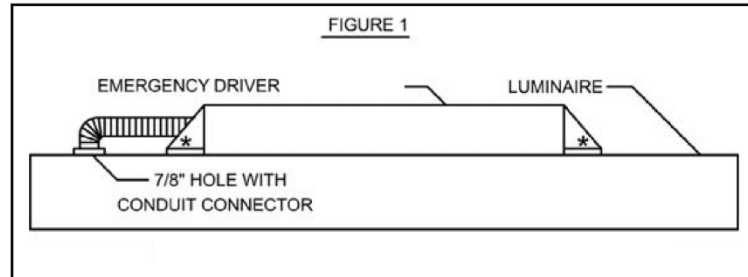

2. MOUNTING THE EMERGENCY LED DRIVER

Perform all wiring with exception of the Violet and Brown wires. Note: wiring must be performed in accordance with the National Electric Code and applicable local codes.

Refer to Figure 2 at right.

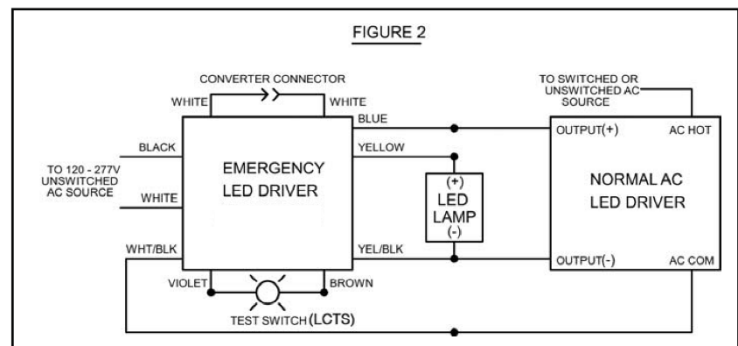

3. INSTALLING THE LED COMBO TEST SWITCH (LCTS)

Recessed Troffer Luminaire – Select a convenient location with proper clearance in the LED Driver cover and drill or punch a 7/8" hole (1/2" knockout). Insert the 7/8" bushing into the hole. Push the plastic tube through the bushing. Route the leads of the LCTS through the plastic tube. Connect the wires from the ELB to the LCTS (Violet to Violet, Brown to Brown).

Refer to Figure 3 at right.

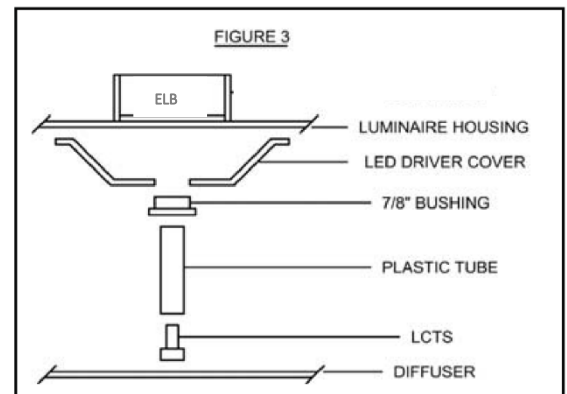

Strip Luminaire – Select a convenient location on the fixture where the LCTS will be visible after installation. Allow for proper clearance inside the fixture and drill or punch a 1/2" hole. Push the LCTS housing into the 1/2" hole and secure with nut. Connect the wires from the ELB to the LCTS (Violet to Violet, Brown to Brown).

Refer to Figure 4 at right.

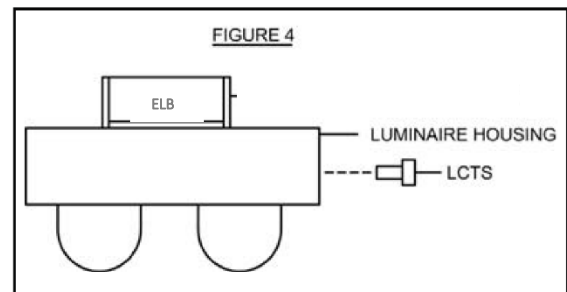

4. WIRING THE AC INPUT

- The ELB and AC LED Driver must be on the same branch circuit.
- The ELB requires an unswitched AC power source of 120 to 277 volts.
- When the ELB is used in a switched luminaire, the AC input to the ELB must be connected to ahead of the luminaire switch (line side of luminaire switch) **Refer to Figure 2.**

5. COMPLETING INSTALLATION

When the installation is complete, switch the AC power ON and join the ELB converter connector.

Refer to Figure 2.