

The 2WXLDZN combo provides a designer outdoor combo. A heavy duty gasket protected housing make the enclosure resistant to corrosive atmospheres, non-hazardous dust, water spray, splash and even hose-downs.

FEATURES

- Dual 120/277 voltage
- Flame-Retardant, High-Impact, Thermoplastic Housing
- Die-cast aluminum mounting canopy included for top or end mount
- Integrated Solid State System
- Constant Current, Controlled Automatic Charger Circuit
- Low-Voltage Battery Cutoff
- Brownout Sensitivity
- 6V long life, maintenance free, rechargeable Nicad battery
- Test Switch
- Led (power On) Indicator
- 3.6 Watts LED per head



2WXLDZN

The 2WXLDZN is ideal in wet locations requiring architectural designs.

WARRANTY

5 Year Warranty

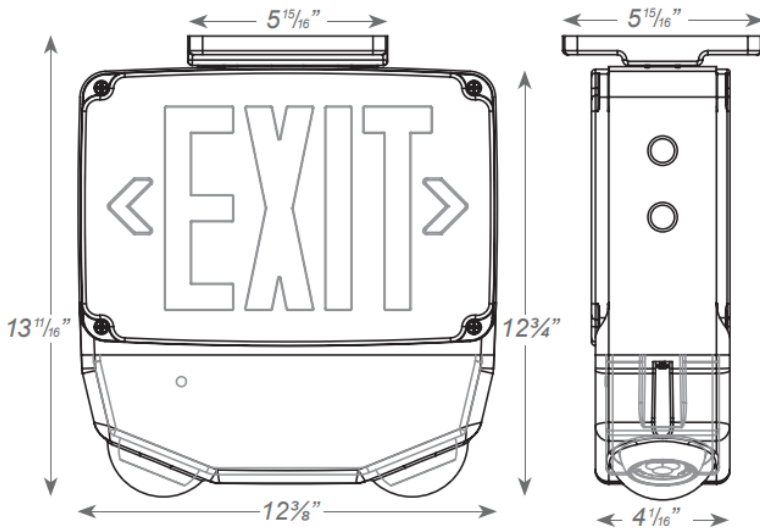

Options:

- * SD - Self Diagnostics
- * RC - Remote Capable
- * HTR - Heater

Series	Faces	Letter Color	Stencil Trim Color	Housing Color	Options
2WXLDZN = LED Combo	1 = Single Face	R= Red	W= White	G = Grey (standard)	-SD = Self Diagnostics
	2 = Double Face	G = Green	B = Black	B = Black	
					W = White